

COMPACT Series

One step shrink wrap machines without tunnel

PackagingSolutions



По вопросам продаж и поддержки обращайтесь:

Алматы (7273)495-231
Ангарск (3955)60-70-56
Архангельск (8182)63-90-72
Астрахань (8512)99-46-04
Барнаул (3852)73-04-60
Белгород (4722)40-23-64
Благовещенск (4162)22-76-07
Брянск (4832)59-03-52
Владивосток (423)249-28-31
Владикавказ (8672)28-90-48
Владимир (4922)49-43-18
Волгоград (844)278-03-48
Вологда (8172)26-41-59
Воронеж (473)204-51-73
Екатеринбург (343)384-55-89

Иваново (4932)77-34-06
Ижевск (3412)26-03-58
Иркутск (395)279-98-46
Казань (843)206-01-48
Калининград (4012)72-03-81
Калуга (4842)92-23-67
Кемерово (3842)65-04-62
Киров (8332)68-02-04
Коломна (4966)23-41-49
Кострома (4942)77-07-48
Краснодар (861)203-40-90
Красноярск (391)204-63-61
Курган (3522)50-90-47
Курск (4712)77-13-04
Липецк (4742)52-20-81

Магнитогорск (3519)55-03-13
Москва (495)268-04-70
Мурманск (8152)59-64-93
Набережные Челны (8552)20-53-41
Нижний Новгород (831)429-08-12
Новокузнецк (3843)20-46-81
Новосибирск (383)227-86-73
Ноябрьск (3496)41-32-12
Омск (3812)21-46-40
Орел (4862)44-53-42
Оренбург (3532)37-68-04
Пенза (8412)22-31-16
Пермь (342)205-81-47
Петрозаводск (8142)55-98-37
Псков (8112)59-10-37

Ростов-на-Дону (863)308-18-15
Рязань (4912)46-61-64
Самара (846)206-03-16
Санкт-Петербург (812)309-46-40
Саранск (8342)22-96-24
Саратов (845)249-38-78
Севастополь (8692)22-31-93
Симферополь (3652)67-13-56
Смоленск (4812)29-41-54
Сочи (862)225-72-31
Ставрополь (8652)20-65-13
Сургут (3462)77-98-35
Сыктывкар (8212)25-95-17
Тамбов (4752)50-40-97
Тверь (4822)63-31-35

Тольятти (8482)63-91-07
Томск (3822)98-41-53
Тула (4872)33-79-87
Тюмень (3452)66-21-18
Улан-Удэ (3012)59-97-51
Ульяновск (8422)24-23-59
Уфа (347)229-48-12
Хабаровск (4212)92-98-04
Чебоксары (8352)28-53-07
Челябинск (351)202-03-61
Череповец (8202)49-02-64
Чита (3022)38-34-83
Якутск (4112)23-90-97
Ярославль (4852)69-52-93

Россия +7(495)268-04-70

Казахстан +7(7172)727-132

Киргизия +996(312)96-26-47

mkv@nt-rt.ru || <https://maripak.nt-rt.ru>

COMPACT Series

One step shrink wrap machines without tunnel

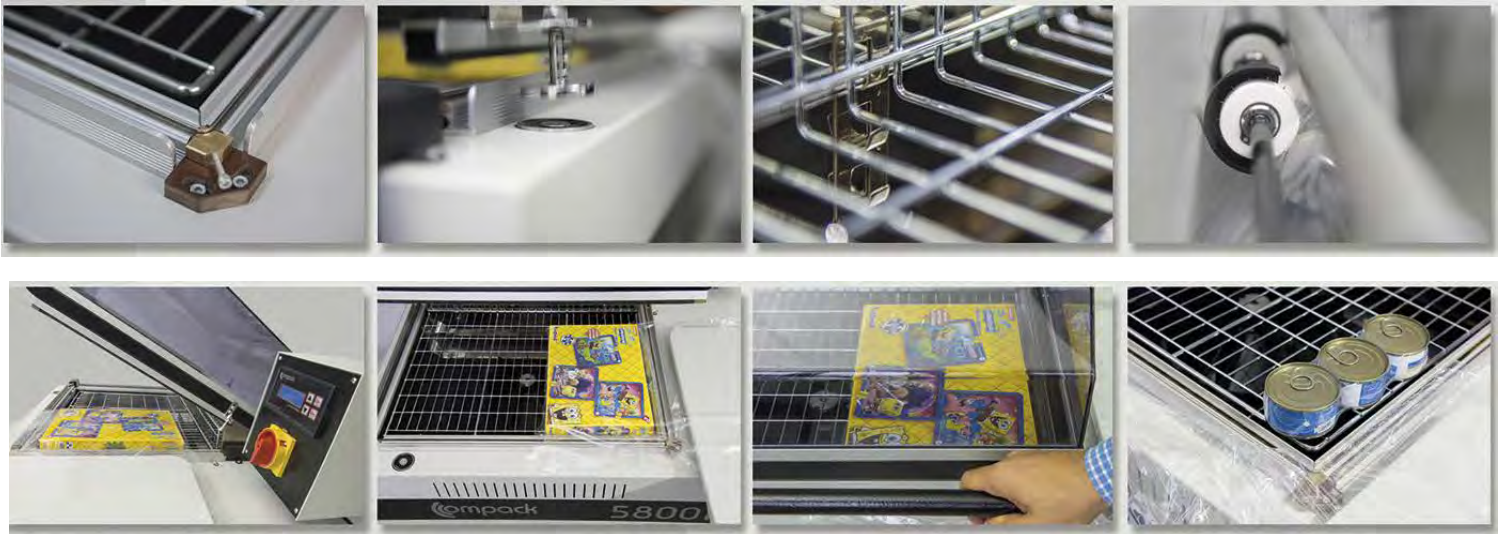

Technical Specifications

Max. Capacity: 5-10 pack / min
Max Roll Diameter: Ø300mm standard
Working Height (E): 860mm (8000-i Series 970mm)
Film Types: POF 7 37micron
 PVC 15-25micron
Max. Product Height: 150mm
 Optionally Higher
Color: Light gray RAL7035

Compact 4500-i

Max Packaging Sizes (WxLxH): 150 x 350 x 150mm
Max. Film Width: 400mm
Installed Power (50-60Hz): 200-240V, 15 Ampere, 1 Phase
Consumption (Max. / Average): 4 kW / 3 kW
Chamber Sizes: 450 x 300 x 250mm
Dimensions (AxBxCxD): 1080x600x1140x270mm
Palletized Size (WxLxH): 800 x 1200 x 770mm
Weight (Net / Gross): 100 kg / 130 kg

Compact 5800-i

250 x 450 x 150mm
 500mm
 200-240V, 17 Ampere 1 Phase
 5 kW / 3 kW
 580 x 440 x 250mm
 1220x730x1140x270mm
 800 x 1200 x 770mm
 120 kg / 150 kg

Compact 7000-i

350 x 550 x 150mm
 600mm
 400V, 13 Ampere 3 Phase
 6 kW / 4 kW
 700 x 510 x 250mm
 1480x860x1140x270mm
 940 x 1590 x 800mm
 151 kg / 205 kg

Compact 8000-i

450 x 650 x 150mm
 700mm
 400V, 17 Ampere, 3 Phase
 9 kW / 5 kW
 810 x 610 x 250mm
 1840x980x1220x270mm
 980 x 1930 x 1220mm
 176 kg / 224 kg

Features:

- Seal & shrink single-step application in the same chamber
- Practical and compact solution for low capacity packaging requirements
- Easily transportable on wheels inside a facility
- Timers and temperature controls by digital control panel
- Magnetic holder keeps the chamber hood closed automatically
- Adjustable perforators for air discharge during shrinkage

Intelligent Sealing System & Advantages:

- Sealing blade power is generated as much as it is needed
- Adaptive temperature power control during variable cycle times
- Start-up power for the sealing blade is controlled with intelligent system.
- Increased duration of composite blade-supports due to efficient heat control
- Sustainable sealing quality and process accuracy by stabilized heat control

Sealing:

- Mechanical switch triggers heating of wire and chamber when the hood is closed
- Sealing is actuated in between wire and silicon rubber by manually closed hood
- Teflon belt covered silicon rubber increase sealing quality and lifespan of silicon
- Sealing wire is embedded into heat-resistant composite fiber
- Solid state relays in electrical cabinet helps operating long-term and quietly

Flexibility:

- Height adjustable package mesh tray for center sealing option
- Adjustable power of sealing blade against different film thickness
- Poly-bagging option (without shrink) by switching off the fan
- Temperature, timer other options are controlled with digital system
- Various language options are available in digital control panel
- Service menu is available in digital control panel
- Film roll holder with easy to slide, load and align each package

Quality:

- Working option without pressured air need
- ISO9001 quality standards with the relevant norm's confirmation
- CE certifications, complies with the latest CE directives
- World-wide approved brands for all mechanical and electrical components
- 1 year warranty for nonwearable parts against manufacturing faults
- 5 years spare part availability

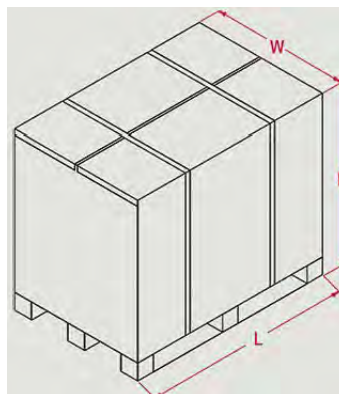

COMPACT HC Series

One step shrink wrap machines without tunnel

PackagingSolutions



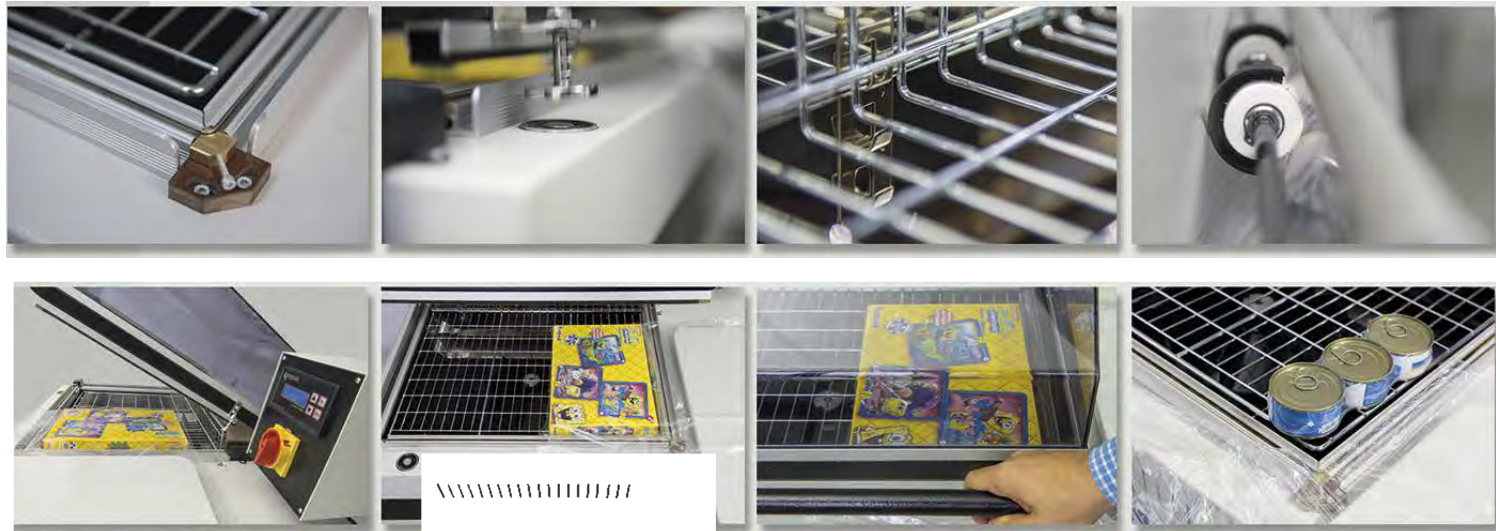

Technical Specifications

Maximum Capacity: 5 10 pack / min
Maximum Roll Diameter: Ø300mm standard
Working Height (E): 860mm
Film Types: 8000 Seres 970mm
 POF 7-37micron
 PVC 15-25m cron
Maximum Product Height: 250mm
Color: Light gray RAL7035

Compack 5800i HC

Maximum Packaging Sizes (WxLxH): 250 x 450 x 250mm
Maximum Film Width: 600mm
Installed Power (50-60Hz): 5 kW, 200-240V, 17 Ampere, 1 Phase
Average Consumption: 3 kW
Chamber Sizes: 580 x 440 x 350mm
Dimensions (AxBxCxD): 1220 x 780 x 1140 x 370mm
Palletized Size (WxLxH): 980 x 1430 x 860mm
Weight (Net / Gross): 135 kg / 190 kg

Compack 8000i HC

450 x 650 x 250mm
 900mm
 9 kW, 400V, 17 Ampere, 3 Phase
 5 kW
 810 x 610 x 350mm
 1810 x 1050 x 1330 x 370mm
 1240 x 2040 x 970mm
 195 kg / 265 kg

Features:

- Seal & shrink singlestep application in the same chamber
- Practical and compact solution for low capacity packaging requirements
- Easily transportable on wheels inside a facility
- Timers and temperature controls by digital control panel
- Magnetic holder keeps the chamber hood closed automatically
- Adjustable perforators for air discharge during shrinkage

Intelligent Sealing System & Advantages:

- Sealing blade power is generated as much as it is needed
- Adaptive temperature power control during variable cycle times
- Start-up power for the sealing blade is controlled with intelligent system.
- Increased duration of composite blade-supports due to efficient heat control
- Sustainable sealing quality and process accuracy by stabilized heat control

Sealing:

- Mechanical switch triggers heating of wire and chamber when the hood is closed
- Sealing is actuated in between wire and silicon rubber by manually closed hood
- Teflon belt covered silicon rubber increase sealing quality and lifespan of silicon
- Sealing wire is embedded into heat-resistant composite fiber
- Solid state relays in electrical cabinet helps operating long-term and quietly

Flexibility:

- Height adjustable package mesh tray for center sealing option
- Adjustable power of sealing blade against different film thickness
- Poly-bagging option (without shrink) by switching off the fan
- Temperature, timer other options are controlled with digital system
- Various language options are available in digital control panel
- Service menu is available in digital control panel
- Film roll holder with easy to slide, load and align each package

Quality:

- Working option without pressured air need
- ISO9001 quality standards with the relevant norm's confirmation
- CE certifications, complies with the latest CE directives
- World-wide approved brands for all mechanical and electrical components
- 1 year warranty for nonwearable parts against manufacturing faults
- 5 years spare part availability

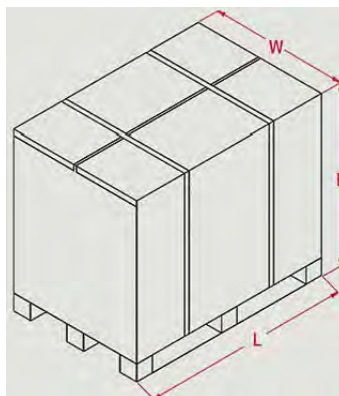

Алматы (7273)495-231
 Ангарск (3955)60-70-56
 Архангельск (8182)63-90-72
 Астрахань (8512)99-46-04
 Барнаул (3852)73-04-60
 Белгород (4722)40-23-64
 Благовещенск (4162)22-76-07
 Брянск (4832)59-03-52
 Владивосток (423)249-28-31
 Владикавказ (8672)28-90-48
 Владимир (4922)49-43-18
 Волгоград (844)278-03-48
 Вологда (8172)26-41-59
 Воронеж (473)204-51-73
 Екатеринбург (343)384-55-89

Иваново (4932)77-34-06
 Ижевск (3412)26-03-58
 Иркутск (395)279-98-46
 Казань (843)206-01-48
 Калининград (4012)72-03-81
 Калуга (4842)92-23-67
 Кемерово (3842)65-04-62
 Киров (8332)68-02-04
 Коломна (4966)23-41-49
 Кострома (4942)77-07-48
 Краснодар (861)203-40-90
 Красноярск (391)204-63-61
 Курган (3522)50-90-47
 Курск (4712)77-13-04
 Липецк (4742)52-20-81

Магнитогорск (3519)55-03-13
 Москва (495)268-04-70
 Мурманск (8152)59-64-93
 Набережные Челны (8552)20-53-41
 Нижний Новгород (831)429-08-12
 Новокузнецк (3843)20-46-81
 Новосибирск (383)227-86-73
 Ноябрьск (3496)41-32-12
 Омск (3812)21-46-40
 Орел (4862)44-53-42
 Оренбург (3532)37-68-04
 Пенза (8412)22-31-16
 Пермь (342)205-81-47
 Петрозаводск (8142)55-98-37
 Псков (8112)59-10-37

Ростов-на-Дону (863)308-18-15
 Рязань (4912)46-61-64
 Самара (846)206-03-16
 Санкт-Петербург (812)309-46-40
 Саранск (8342)22-96-24
 Саратов (845)249-38-78
 Севастополь (8692)22-31-93
 Симферополь (3652)67-13-56
 Смоленск (4812)29-41-54
 Сочи (862)225-72-31
 Ставрополь (8652)20-65-13
 Сургут (3462)77-98-35
 Сыктывкар (8212)25-95-17
 Тамбов (4752)50-40-97
 Тверь (4822)63-31-35

Тольятти (8482)63-91-07
 Томск (3822)98-41-53
 Тула (4872)33-79-87
 Тюмень (3452)66-21-18
 Улан-Удэ (3012)59-97-51
 Ульяновск (8422)24-23-59
 Уфа (347)229-48-12
 Хабаровск (4212)92-98-04
 Чебоксары (8352)28-53-07
 Челябинск (351)202-03-61
 Череповец (8202)49-02-64
 Чита (3022)38-34-83
 Якутск (4112)23-90-97
 Ярославль (4852)69-52-93

Россия +7(495)268-04-70

Казахстан +7(7172)727-132

Киргизия +996(312)96-26-47

mkv@nt-rt.ru || <https://maripak.nt-rt.ru>