

IMPACT PRO 20-40 Series

Fully automated continuous sealer packaging machine

PackagingIntelligence



По вопросам продаж и поддержки обращайтесь:

Алматы (7273)495-231
Ангарск (3955)60-70-56
Архангельск (8182)63-90-72
Астрахань (8512)99-46-04
Барнаул (3852)73-04-60
Белгород (4722)40-23-64
Благовещенск (4162)22-76-07
Брянск (4832)59-03-52
Владивосток (423)249-28-31
Владикавказ (8672)28-90-48
Владимир (4922)49-43-18
Волгоград (844)278-03-48
Вологда (8172)26-41-59
Воронеж (473)204-51-73
Екатеринбург (343)384-55-89
Иваново (4932)77-34-06
Ижевск (3412)26-03-58
Иркутск (395)279-98-46
Казань (843)206-01-48

Калининград (4012)72-03-81
Калуга (4842)92-23-67
Кемерово (3842)65-04-62
Киров (8332)68-02-04
Коломна (4966)23-41-49
Кострома (4942)77-07-48
Краснодар (861)203-40-90
Красноярск (391)204-63-61
Курган (3522)50-90-47
Курск (4712)77-13-04
Липецк (4742)52-20-81
Магнитогорск (3519)55-03-13
Москва (495)268-04-70
Мурманск (8152)59-64-93
Набережные Челны (8552)20-53-41
Нижний Новгород (831)429-08-12
Новокузнецк (3843)20-46-81
Новосибирск (383)227-86-73
Ноябрьск (3496)41-32-12

Омск (3812)21-46-40
Орел (4862)44-53-42
Оренбург (3532)37-68-04
Пенза (8412)22-31-16
Пермь (342)205-81-47
Петрозаводск (8142)55-98-37
Псков (8112)59-10-37
Ростов-на-Дону (863)308-18-15
Рязань (4912)46-61-64
Самара (846)206-03-16
Санкт-Петербург (812)309-46-40
Саранск (8342)22-96-24
Саратов (845)249-38-78
Севастополь (8692)22-31-93
Симферополь (3652)67-13-56
Смоленск (4812)29-41-54
Сочи (862)225-72-31
Ставрополь (8652)20-65-13
Сургут (3462)77-98-35

Сыктывкар (8212)25-95-17
Тамбов (4752)50-40-97
Тверь (4822)63-31-35
Тольятти (8482)63-91-07
Томск (3822)98-41-53
Тула (4872)33-79-87
Тюмень (3452)66-21-18
Улан-Удэ (3012)59-97-51
Ульяновск (8422)24-23-59
Уфа (347)229-48-12
Хабаровск (4212)92-98-04
Чебоксары (8352)28-53-07
Челябинск (351)202-03-61
Череповец (8202)49-02-64
Чита (3022)38-34-83
Якутск (4112)23-90-97
Ярославль (4852)69-52-93

Россия +7(495)268-04-70

Казахстан +7(7172)727-132

Киргизия +996(312)96-26-47

mkv@nt-rt.ru || <https://maripak.nt-rt.ru>

IMPACT PRO 20-40 Series

Fully automated continuous sealer packaging machine



Technical Specifications

Sealer Bar Opening: 250mm
Max Conv. Speed: 30 mt/min (adjustable)
Max. Cycle: 60 cycle/min (example IN A4 form)
Max. Roll Diameter: 300mm standard (adjustable)
Working Height (E): 860mm
Air Consumption: No need*
Film Types: 7-40 µm POF, PP, PE + V⁺ Knife
 40-60 µm PE, OPP + W⁺ Knife
Color: Customised (Mixed grey + RAL7015 + RAL7010)

* Kissing Belt requires air. Air requirement: 6 bar, Air Consumption 0,5 liters / cycle

Advantages:

- Very compact and new esthetic 'Pro' design
- Continuous side sealer provides unlimited length packaging ability
- Very fast and flawless sealing property by Servo driven vertical sealer
- Easy to integrate with the production lines directly
- Recordable and re-callable package parameter settings

Features:

- Automatic length detection by sensor synchronized encoder control
- User-friendly color touch screen operator panel
- Automatic packaging film drive with tension control
- Automatic trim winder with tension control
- Feeding frequency control by sensor detection and PLC control

Sealing:

- CenterSeal property provides accurate and linear sealing line
- Adjustable precision and pressure on cutting and sealing force
- PID controlled sealing temperature inserted by touch panel
- Alternative sealing blade structures for various packaging material
- Product clearance control under seal bar by sensor

Flexibility:

- Easily adjustable wrt varying product sizes and capacity
- Various language options and adaptable touch keyboard
- Memory Receipt property for prompt adjustments
- Perfect sealing blade design compatible with varying thicknesses

Impact 20 Pro

Max. Packaging Sizes (Width x Length x Height): 150 x Unlimited x 200mm
Cross Sealer Length: 300mm
Conveyor Belt Width (D): 200mm
Max. Film Width: 650mm
Installed Power (50-60Hz): 400V, 6 Ampere, 3 Phase
Consumption (Max. / Average): 6 kW / 3 kW
Dimensions (AxBxC): 1310 x 2080 x 1895mm
Palletized Size (AxBxC): 1200 x 2270 x 1675mm
Weight (Net / Gross): 624 kg / 690 kg

Impact 40 Pro

350 x Unlimited x 200mm
530mm
400mm
650mm
400V, 6 Ampere, 3 Phase
6 kW / 3 kW
1510 x 2080 x 1895mm
1400 x 2270 x 1675mm
780 kg / 860 kg

Optional:

- Solenoid actuator for side sealer: Free of compressed air requirement
- Printed film applicability by marker detection sensor and programming
- Center folder system for single layer flat film applicator
- Ability to control additional conveyors by inverters
- Linking Belt (compressed air is require*)

Quality:

- ISO9001 quality standards with the relevant norm's confirmation
- World-wide brands for all mechanical, electrical and pneumatic components
- CE certifications, complies with the latest CE directives
- One year warranty on non-wearable parts (extendable)
- Manufacturer's guarantee for spare part stock and after sales support
- Manufacturer's guarantee for spare part stock availability up to 5 years



IMPACT PRO 60-80-100 Series

Fully automated continuous sealer packaging machine

PackagingIntelligence



IMPACK PRO 60-80-100 Series

Fully automated continuous sealer packaging machine



Technical Specifications

Sealer Bar Opening: 250mm
Max. Conv. Speed: 30 mt/min (adjustable)
Max. Cycle: 60 cycle/min (example: DIN A4 format)
Max. Roll Diameter: 300mm standard (adjustable)
Working Height (E): 860mm
Air Consumption: No need*
Film Types: 7-40 µm POF, PP, PE + V-Knife
 40-60 µm PE, OPP + W-Knife
Color: Customised (Mixed grey + RAL7015 + RAL7010)

Impack 60 Pro

Max. Packaging Sizes (WxLxH): 550 x Unlimited x 200mm
Min. Packaging Width: 150mm
Conveyor Belt Width (D): 600mm
Max. Film Width: 800mm
Installed Power (50-60Hz): 400V, 6 Ampere, 3 Phase
Consumption (Max. / Average): 6 kW / 3 kW
Dimensions (AxBxC): 1930 x 2640 x 2000mm
Palletized Size (AxBxC): 2130 x 2955 x 1750mm
Weight (Net / Gross): 1050 kg / 1170 kg

Impack 80 Pro

750 x Unlimited x 200mm
 200mm
 800mm
 950mm
 400V, 8 Ampere, 3 Phase
 7 kW / 4 kW
 2230 x 2640 x 2000mm
 2430 x 2955 x 1750mm
 1410 kg / 1550 kg

Impack 100 Pro

950 x Unlimited x 200mm
 400mm
 1000mm
 1100mm
 400V, 8 Ampere, 3 Phase
 7 kW / 4 kW
 2530 x 2640 x 2000mm
 2730 x 2955 x 1750mm
 1960 kg / 2180 kg

*Kissing Belt requires air. Air requirement: 6 Bar, Air Consumption: 1 liters / cycle

Advantages:

- Very compact and new esthetic 'Pro' design
- Continuous side sealer provides unlimited length packaging ability
- Very fast and flawless sealing property by Servo driven vertical sealer
- Easy to integrate with the production lines directly
- Recordable and recallable package parameter settings

Features:

- Automatic length detection by sensor synchronized encoder control
- Userfriendly color touch screen operator panel
- Automatic packaging film drive with tension control
- Automatic trim winder with tension control
- Feeding frequency control by sensor detection and PLC control

Sealing:

- Center Seal property provides accurate and linear sealing line
- Adjustable precision and pressure on cutting and sealing force
- PID controlled sealing temperature inserted by touch panel
- Alternative sealing blade structures for various packaging material
- Product clearance control under seal bar by sensor

Flexibility:

- Easily adjustable wrt varying product sizes and capacity
- Various language options and adaptable touch keyboard
- Memory Receipt property for prompt adjustments
- Perfect sealing blade design compatible with varying thicknesses

Optional:

- Solenoid actuator for side sealer: Free of compressed air requirement
- Printed film applicability by marker detection sensor and programming
- Center folder system for single layer flat film application
- Ability to control additional conveyors by inverters
- Linking Belt (compressed air is require*)

Quality:

- ISO9001 quality standards with the relevant norm's confirmation
- World wide brands for all mechanical, electrical and pneumatic components
- CE certifications, complies with the latest CE directives
- One year warranty on nonwearable parts (extendable)
- Manufacturer's guarantee for spare part stock and after sales support
- Manufacturer's guarantee for spare part stock availability up to 5 years

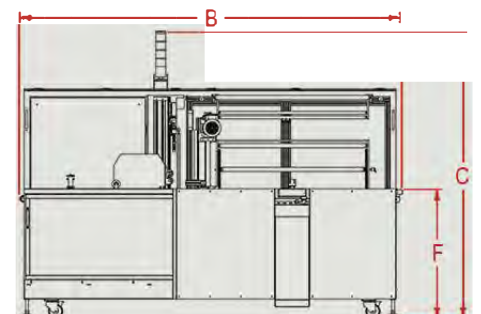
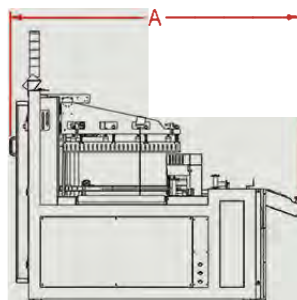
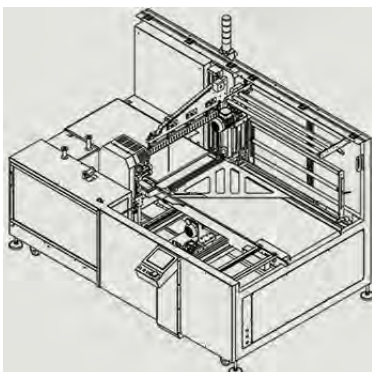
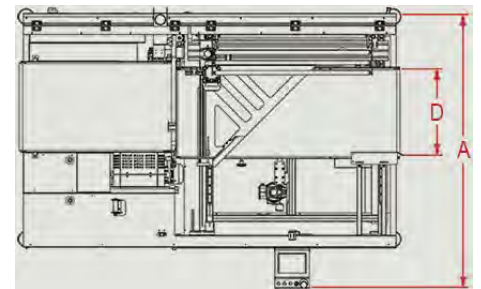

По вопросам продаж и поддержки обращайтесь:

Алматы (7273)495-231
Ангарск (3955)60-70-56
Архангельск (8182)63-90-72
Астрахань (8512)99-46-04
Барнаул (3852)73-04-60
Белгород (4722)40-23-64
Благовещенск (4162)22-76-07
Брянск (4832)59-03-52
Владивосток (423)249-28-31
Владикавказ (8672)28-90-48
Владимир (4922)49-43-18
Волгоград (844)278-03-48
Вологда (8172)26-41-59
Воронеж (473)204-51-73
Екатеринбург (343)384-55-89
Иваново (4932)77-34-06
Ижевск (3412)26-03-58
Иркутск (395)279-98-46
Казань (843)206-01-48

Калининград (4012)72-03-81
Калуга (4842)92-23-67
Кемерово (3842)65-04-62
Киров (8332)68-02-04
Коломна (4966)23-41-49
Кострома (4942)77-07-48
Краснодар (861)203-40-90
Красноярск (391)204-63-61
Курган (3522)50-90-47
Курск (4712)77-13-04
Липецк (4742)52-20-81
Магнитогорск (3519)55-03-13
Москва (495)268-04-70
Мурманск (8152)59-64-93
Набережные Челны (8552)20-53-41
Нижний Новгород (831)429-08-12
Новокузнецк (3843)20-46-81
Новосибирск (383)227-86-73
Ноябрьск (3496)41-32-12

Омск (3812)21-46-40
Орел (4862)44-53-42
Оренбург (3532)37-68-04
Пенза (8412)22-31-16
Пермь (342)205-81-47
Петрозаводск (8142)55-98-37
Псков (8112)59-10-37
Ростов-на-Дону (863)308-18-15
Рязань (4912)46-61-64
Самара (846)206-03-16
Санкт-Петербург (812)309-46-40
Саранск (8342)22-96-24
Саратов (845)249-38-78
Севастополь (8692)22-31-93
Симферополь (3652)67-13-56
Смоленск (4812)29-41-54
Сочи (862)225-72-31
Ставрополь (8652)20-65-13
Сургут (3462)77-98-35

Сыктывкар (8212)25-95-17
Тамбов (4752)50-40-97
Тверь (4822)63-31-35
Тольятти (8482)63-91-07
Томск (3822)98-41-53
Тула (4872)33-79-87
Тюмень (3452)66-21-18
Улан-Удэ (3012)59-97-51
Ульяновск (8422)24-23-59
Уфа (347)229-48-12
Хабаровск (4212)92-98-04
Чебоксары (8352)28-53-07
Челябинск (351)202-03-61
Череповец (8202)49-02-64
Чита (3022)38-34-83
Якутск (4112)23-90-97
Ярославль (4852)69-52-93

Россия +7(495)268-04-70

Казахстан +7(7172)727-132

Киргизия +996(312)96-26-47

mkv@nt-rt.ru || <https://maripak.nt-rt.ru>