

# RLS ePro Series

Electric servo driven L sealer packaging machine

*PackagingIntelligence*



Алматы (7273)495-231  
Ангарск (3955)60-70-56  
Архангельск (8182)63-90-72  
Астрахань (8512)99-46-04  
Барнаул (3852)73-04-60  
Белгород (4722)40-23-64  
Благовещенск (4162)22-76-07  
Брянск (4832)59-03-52  
Владивосток (423)249-28-31  
Владикавказ (8672)28-90-48  
Владимир (4922)49-43-18  
Волгоград (844)278-03-48  
Вологда (8172)26-41-59  
Воронеж (473)204-51-73  
Екатеринбург (343)384-55-89

Иваново (4932)77-34-06  
Ижевск (3412)26-03-58  
Иркутск (395)279-98-46  
Казань (843)206-01-48  
Калининград (4012)72-03-81  
Калуга (4842)92-23-67  
Кемерово (3842)65-04-62  
Киров (8332)68-02-04  
Коломна (4966)23-41-49  
Кострома (4942)77-07-48  
Краснодар (861)203-40-90  
Красноярск (391)204-63-61  
Курган (3522)50-90-47  
Курск (4712)77-13-04  
Липецк (4742)52-20-81

Магнитогорск (3519)55-03-13  
Москва (495)268-04-70  
Мурманск (8152)59-64-93  
Набережные Челны (8552)20-53-41  
Нижегород (831)429-08-12  
Новокузнецк (3843)20-46-81  
Новосибирск (383)227-86-73  
Ноябрьск (3496)41-32-12  
Омск (3812)21-46-40  
Орел (4862)44-53-42  
Оренбург (3532)37-68-04  
Пенза (8412)22-31-16  
Пермь (342)205-81-47  
Петрозаводск (8142)55-98-37  
Псков (8112)59-10-37

Ростов-на-Дону (863)308-18-15  
Рязань (4912)46-61-64  
Самара (846)206-03-16  
Санкт-Петербург (812)309-46-40  
Саранск (8342)22-96-24  
Саратов (845)249-38-78  
Севастополь (8692)22-31-93  
Симферополь (3652)67-13-56  
Смоленск (4812)29-41-54  
Сочи (862)225-72-31  
Ставрополь (8652)20-65-13  
Сургут (3462)77-98-35  
Сыктывкар (8212)25-95-17  
Тамбов (4752)50-40-97  
Тверь (4822)63-31-35

Тольятти (8482)63-91-07  
Томск (3822)98-41-53  
Тула (4872)33-79-87  
Тюмень (3452)66-21-18  
Улан-Удэ (3012)59-97-51  
Ульяновск (8422)24-23-59  
Уфа (347)229-48-12  
Хабаровск (4212)92-98-04  
Чебоксары (8352)28-53-07  
Челябинск (351)202-03-61  
Череповец (8202)49-02-64  
Чита (3022)38-34-83  
Якутск (4112)23-90-97  
Ярославль (4852)69-52-93

Россия +7(495)268-04-70

Казахстан +7(7172)727-132

Киргизия +996(312)96-26-47

mkv@nt-rt.ru | | <https://maripak.nt-rt.ru>

# RLS ePro Series

Electric servo driven L sealer packaging machine



## Technical Specifications

**Minimum Package Width:** 50mm  
**Conveyor Speed:** 30 m/min (adjustable)  
**Maximum Cycle:** 30 cycle / min  
**Maximum Roll Diameter:** 300mm standard (adjustable)  
**Working Height (E):** 860mm  
**Compressed Air:** No need\*\*  
**Film Thickness:** 10 - 40 mikron\*  
**Film Types:** POF, PE, OPP, CPP, PP  
**Color:** Gri karşım + RAL7010 + RAL7015

**Maximum Packaging Sizes (Width x Length x Height):** 350 x 450 x 120 mm  
**Cross Sealer Length:** 580 x 440mm  
**Conveyor Belt Width (D):** 400mm  
**Maximum Film Width:** 650mm  
**Installed Power (50-60Hz):** 4 kW, 400V, 6 Ampere, 3 Phase  
**Average Consumption:** 3 kW  
**Dimensions (AxBxC):** 1240 x 2080 x 1890mm  
**Palletized Size (AxBxC):** 1400 x 2270 x 1680mm  
**Weight (Net / Gross):** 748 kg / 828 kg

## RLS ePro 80x60

550 x 750 x 120 mm  
 800 x 600mm  
 600mm  
 1000mm  
 5 kW, 400V, 6 Ampere, 3 Phase  
 3 kW  
 1920 x 2880 x 2000mm  
 2000 x 3155 x 1820mm  
 1050 kg / 1240 kg

\*\* Optional belt operates with pressured air Air requirement 6 Bar, Air Consumption 1 liters / cycle

\* Depending on the film type, the thickness may change

## Advantages:

- Feasible fully automatic solution for average capacity requirements
- Easy to integrate with the production lines directly
- Easy to reach spacious design for both maintenance and adjustments

## Features:

- Automatic length detection by sensor synchronized with encoder control
- User-friendly colorful touch screen operator panel
- Automatic packaging film drive with tension control
- Automatic trim winder with tension control
- Linear sealing ability for various heights by Center Seal system
- Feeding frequency control by sensor detection and PLC command
- Ability to read instant (or total) realized capacity by counter
- L bar opening limit control by electric servo system
- L bar sealing pressure control system
- Trimmer system with safety sliding window with safety sensors
- Roll nesting unit with CE compatible safety doors
- Fixed legs and casters together for both option
- Visual and audio warning signal for film tension variance detection
- Strong needlewheel frame structure for air discharge perforation

## Sealing:

- Fully Teflon coated L shaped hot bar knife system
- PID controlled sealing temperature inserted by touch panel
- Alternative sealing blade structures for various packaging material
- Product clearance control under seal bar by sensor

## Flexibility:

- Easily adjustable for varying product sizes and capacity requirements
- Various language options and adaptable touch keyboard
- Recordable and recallable product value adjustments
- User friendly designed trim winder for easy and prompt trim unloading
- Separated film roll cabinet for easy and prompt loading
- On screen adjustable frontal and hinder gaps

## Optional:

- Proper passage of short products by Linking Conveyor
- Printed Film applicability by marker detection sensor and programming
- Ability to use single layer flat film by CenterFolding Unit
- Ability to control additional conveyors by inverters

## Quality:

- ISO 9001 quality standards with the relevant norm's confirmation
- Worldwide brands for all mechanical, electrical and pneumatic components
- CE certifications, complies with the latest CE directives
- One year warranty on nonwearable parts (extendable)
- Manufacturer's guarantee for spare part stock and after sales support
- Manufacturer's guarantee for spare part stock availability up to 5 years

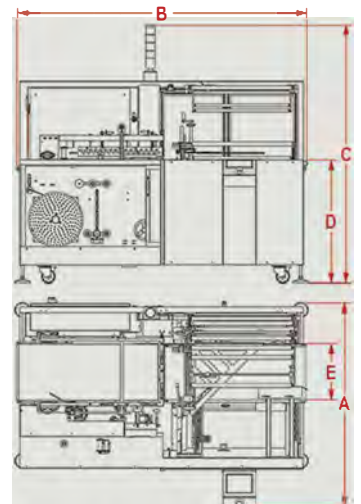
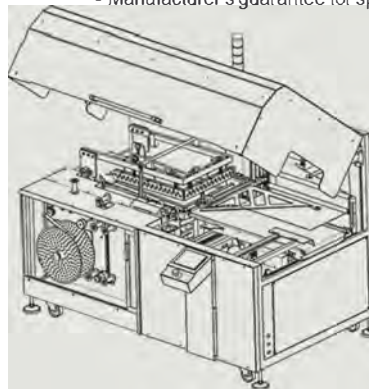

ISO 9001 2000 REGISTERED COMPANY

По вопросам продаж и поддержки обращайтесь:

Алматы (7273)495-231  
Ангарск (3955)60-70-56  
Архангельск (8182)63-90-72  
Астрахань (8512)99-46-04  
Барнаул (3852)73-04-60  
Белгород (4722)40-23-64  
Благовещенск (4162)22-76-07  
Брянск (4832)59-03-52  
Владивосток (423)249-28-31  
Владикавказ (8672)28-90-48  
Владимир (4922)49-43-18  
Волгоград (844)278-03-48  
Вологда (8172)26-41-59  
Воронеж (473)204-51-73  
Екатеринбург (343)384-55-89  
Иваново (4932)77-34-06  
Ижевск (3412)26-03-58  
Иркутск (395)279-98-46  
Казань (843)206-01-48

Калининград (4012)72-03-81  
Калуга (4842)92-23-67  
Кемерово (3842)65-04-62  
Киров (8332)68-02-04  
Коломна (4966)23-41-49  
Кострома (4942)77-07-48  
Краснодар (861)203-40-90  
Красноярск (391)204-63-61  
Курган (3522)50-90-47  
Курск (4712)77-13-04  
Липецк (4742)52-20-81  
Магнитогорск (3519)55-03-13  
Москва (495)268-04-70  
Мурманск (8152)59-64-93  
Набережные Челны (8552)20-53-41  
Нижний Новгород (831)429-08-12  
Новокузнецк (3843)20-46-81  
Новосибирск (383)227-86-73  
Ноябрьск (3496)41-32-12

Омск (3812)21-46-40  
Орел (4862)44-53-42  
Оренбург (3532)37-68-04  
Пенза (8412)22-31-16  
Пермь (342)205-81-47  
Петрозаводск (8142)55-98-37  
Псков (8112)59-10-37  
Ростов-на-Дону (863)308-18-15  
Рязань (4912)46-61-64  
Самара (846)206-03-16  
Санкт-Петербург (812)309-46-40  
Саранск (8342)22-96-24  
Саратов (845)249-38-78  
Севастополь (8692)22-31-93  
Симферополь (3652)67-13-56  
Смоленск (4812)29-41-54  
Сочи (862)225-72-31  
Ставрополь (8652)20-65-13  
Сургут (3462)77-98-35

Сыктывкар (8212)25-95-17  
Тамбов (4752)50-40-97  
Тверь (4822)63-31-35  
Тольятти (8482)63-91-07  
Томск (3822)98-41-53  
Тула (4872)33-79-87  
Тюмень (3452)66-21-18  
Улан-Удэ (3012)59-97-51  
Ульяновск (8422)24-23-59  
Уфа (347)229-48-12  
Хабаровск (4212)92-98-04  
Чебоксары (8352)28-53-07  
Челябинск (351)202-03-61  
Череповец (8202)49-02-64  
Чита (3022)38-34-83  
Якутск (4112)23-90-97  
Ярославль (4852)69-52-93

Россия +7(495)268-04-70

Казахстан +7(7172)727-132

Киргизия +996(312)96-26-47

[mkv@nt-rt.ru](mailto:mkv@nt-rt.ru) || <https://maripak.nt-rt.ru>